

**Approval Sheet for
Lithium Thionyl Chloride Battery Datasheet**

Model: ER14250

ER14250

Product Specification

Specification Approval Sheet

Model: ER14250

Prepared By/Date	Checked By/Date	Approved By/Date

	Confirmation	Date
Customer Approval		

Note: 1. Kindly please sign on the above and send it back to us if the sample is approved.
2. Kindly please contact us as soon as possible if the sample isn't approved. Thanks!

1.Model ER14250 Bobbin type

2.Specification

1) Nominal voltage	3.6V
2) Nominal capacity	1200mAh(0.5mA / 2.0V)
3) Discharge end-voltage	2.0V
4) Operating voltage	3.3V(330Ω, in 5s)
5) Max constant discharge current	50mA
6) Max. pulse current	100mA
7) Ambient temperature range	-55 ~ +85
8) Storage life	≥10 year, Yearly self-discharge ≤ 1%

3. Appearance & Dimension/Weight

1) Appearance:	Cylinder Shape
2) Max dimension :	φ14.5×h25.0mm
3) Max weight:	11g

4. Performance Testing

Unless other request s, all tests are carried out in ambient temperature 20±5 .

Tests should be made within 45 days after receipt of the batteries.

Quality Data Inspection

Item	Measuring Procedure	Standard
1.Appearance	Visual check	Clean, unscratched and clearly labeled
2.Dimensions	Measured by calipers with precision of 0.02mm	Max.φ14.5×25.0mm
3.Weight	Weighed by balance with precision of 0.1g	Max.11g
4.Open-circuit voltage	Measure by volt-meter with precision of 0.01V	≥3.65V
5.Operating voltage	Measure by volt-meter with precision of 0.01V, connecting an impedance of 1200Ω in series, Reaching the target voltage in 5 seconds.	≥3.30V
6.Nominal discharge	1.1KΩ, 20±2%, Constant discharge to 2.0V.	≥900mAh
7.Rapid discharge	330Ω, 20±2%, Constant discharge to 2.0V..	≥700mAh
8. Discharge at high temperature	Put battery in constant ambient temperature of 55±2% for 16 hours, discharge at 1.1KΩ to 2.0V/cell..	≥950mAh
9.Discharge at low temperature	Put battery in constant ambient temperature of -40±2% for 16 hours, discharge at 1.1KΩ to 2.0V/cell	≥450mAh
10.Charge	Prohibited	Prohibited
11.Over-discharge	Prohibited	Prohibited
12.Self discharge	Store the batteries at constant temperature of 20±5, Measure the nominal capacity yearly for 10 years.	≤1%

SPECIFICATION

Model:ER14250

Thionyl Chloride Lithium Battery

● **Characteristics:**

- ▲ Nominal capacity (0.5mA to 2.0V).....1.2Ah
- ▲ Nominal voltage.....3.6V
- ▲ Max. Continuous current.....50mA
- ▲ Max. Pulse current.....100mA
- ▲ Weight.....10g
- ▲ Dimension..... ϕ 14.5*25.0mm
- ▲ Operating temperature range.....-55°C ~ +85°C

● **Terminals available:**

- AX.....axial leads
- T.....welding pins
- P.....plastic plug

● **Special design is acceptable**

◆ **Data above is for reference**

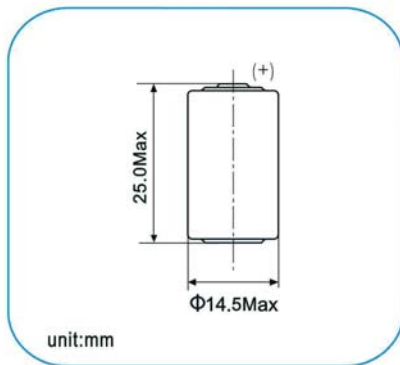

Li-SOCl₂

● **Characteristic curves**

